

LENTO 10

PHOTOELECTRIC SMOKE ALARM

10 10 YEAR BATTERY
NO BATTERY CHANGES EVER



LENTO 10 BY PAOLA SUHONEN is a battery powered smoke alarm for domestic use. It comes with an integrated, non-replaceable Lithium Metal battery that last for 10 years, which is the maximum recommended lifetime for any smoke detector. Automatic power activation upon installation, no user dependent battery replacement during the lifetime of the product and a 10 year end of life indicator secure that users are enjoying highest effective fire safety at home for 10 years.

Key features also include easier to set mounting plate, automatic self testing, entire front surface as a test button and additional 3M adhesive tape for easier and faster installation.

Lento smoke alarm utilizes photoelectric detection technology to sense smoke from different types of fires. Unit's photoelectric (optical) detection method works by sensing infrared rays scattered by visible smoke particles. The smoke alarm is equipped with a self diagnostic and checking feature to ensure correct operation through its service life of 10 years.

The device operates so that when the smoke is present, device will release a loud and continuous warning siren to alert residents.

To avoid unintentional alarms, device will run assuring checks by sampling the air several times.

However if false alarms occur, the smoke alarm is equipped with a Silence-function, which silences the alarm temporarily for eight minutes. Smoke alarm will give a warning signal despite of the silence function if heavy smoke occurs.

Lento 10 smoke alarm comes with integrated CR17450 Lithium Manganese Dioxide battery and it is tested to secure 10 years of operation lifetime. When batteries come to the end of life, the smoke alarm will release short beeps to warn low batteries. Low battery warning will continue for at least one month before the batteries drain completely.

FEATURES & SPECIFICATIONS

10 years non-replaceable Lithium Metal battery for highest effective fire safety at home.

Automatic power activation upon installation.

Whole surface works as a test button for more convenient regular testing of smoke alarm's correct functioning.

Alternative 3M adhesive ceiling install option in addition to the screw installation option. Super strong 3M VHB® provides easier and reliable installation for even ceiling surfaces.

Silence function to silence false alarms and temporarily desensitize the smoke alarm.

Self-diagnostics tests condition of smoke sensing parts and circuitry.

Battery status monitor with 10 years end of life indicator.

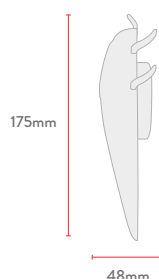
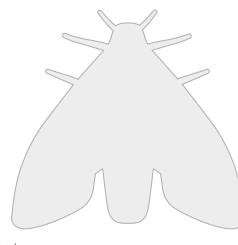

Sensing Element	Photoelectric
Operating environment	Domestic
Operating voltage	9V
Current consumption	15mA operational
Sound volume	85dB at a distance of 3m
Operating temperature	0°C – 45 °C
Maximum humidity	90%
Holding temperature of 3M fixing tape	-35 °C – 93 °C
Battery	1x CR17450 Lithium Manganese Dioxide battery (non-replaceable)
Weight	137g

AVAILABLE MODELS



J4C-02
LENTO 10 BLACK
EAN 6 430038 437938
TARIC 8531103000



J4C-03
LENTO 10 WHITE
EAN 6 430038 437945
TARIC 8531103000



J4C-24
LENTO 10 LIGHT GREEN
EAN 6 430038 437952
TARIC 8531103000



J4C-25
LENTO 10 SILVER GREY
EAN 6 430038 437914
TARIC 8531103000



J4C-23
LENTO 10 ROSA
EAN 6 430038 437921
TARIC 8531103000

INSTALLATION The smoke alarm can be installed in two different ways: **A)** fast installation method with included two-sided 3M tape. **B)** by installing the smoke alarm with screws (included). Fast installation method will take approximately 30 seconds. Further installation instructions are provided with the manual which is included in the package.

TESTING & MAINTENANCE The smoke alarm comes with an internal self-test function. Additionally, the alarm can be and should be regularly tested by the user on a monthly basis. Testing is easy and will provide immediate feedback. Smoke alarm should be cleaned by vacuum cleaning at least once per year for maintenance.

WARNINGS & CAUTIONS This smoke alarm won't detect fire from areas where the smoke cannot reach the alarm.

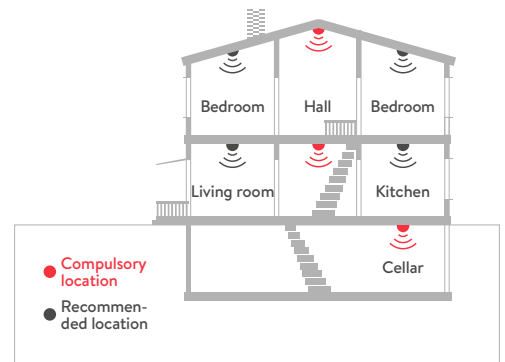

PACKAGING

Set of 24

Weight: 9kg
Quantity of Units: 24
Volume: 0.087 m³

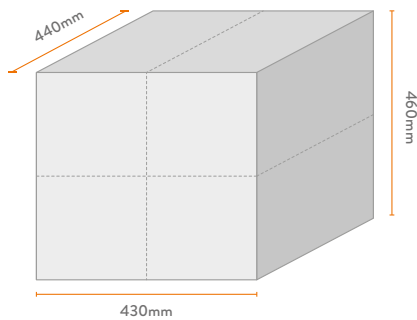

Set of 6

Weight: 2kg
Quantity of Units: 6

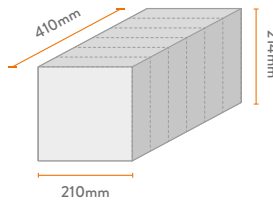

Product packaging

Weight: 0.3kg
Quantity of Units: 1

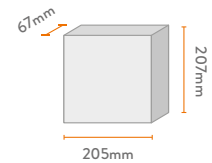

AVAILABLE MANUAL LANGUAGES

Croatian	French	Russian
Czech	German	Slovak
Danish	Icelandic	Swedish
Dutch	Italian	
English	Latvian	
Estonian	Lithuanian	
Finnish	Norwegian	

MANUFACTURER



Jalo Helsinki Oy
PL 131, 00181, Helsinki, Finland
www.jalohelsinki.fi
support@jalohelsinki.fi
www.facebook.com/jalohelsinki

